



airbond



## Airbond Splicers

### 182 Series Splicers

GTW Developments Group Ltd., Unit 1, Pavilion Industrial Estate, Pontypool, UK, NP4 6NF

Tel. +44 1495 755661

Fax. +44 1495 752619

Web: [www.airbondsplicer.com](http://www.airbondsplicer.com)

Email: [enquiries@airbondsplicer.com](mailto:enquiries@airbondsplicer.com)

© GTW Developments Ltd., 2020

No part of this publication may be copied or reproduced, by means electronic, mechanical, photocopy, recording or stored in a retrieval system or transmitted in any form or by any otherwise without the prior permission of GTW Developments Ltd. The Pentwyn Splicers logo is a registered trade mark, property of GTW Developments Ltd.

<b>CONTENTS</b>	
The new generation Airbond splicers - background	3
Model 182 splicers; summary	4
Getting started	5
Splicer threading	8
Optimising splicing performance	9
Important service information	14
General product information	15
182 Series: Model range	19
Model 182 maintenance and repair	22
Compressed air – safety aspects	39
Compressed air - noise	41
Troubleshooting	42
Parts list	45
Exploded diagram	48

## The new-generation Airbond splicers

Airbond has a well-established reputation for supplying tough, reliable splicers. We have achieved this reliability by developing simple designs, and by the use of rugged components.

We have now moved on; our products are now even simpler, and even stronger. We've done this by investing in cutting-edge new additive-manufacturing (3d printing) technology.

From 2020 onward, all Airbond products will be printed, in materials which are more durable than those used in the past.

The first generation of printed products will be familiar to our customers; they are direct replacements for the existing products - identical in shape and function.

The Model 181 is the printed equivalent of the long-established 111.

## Model 182

The multi-purpose auto-cut splicer for low-count synthetics and staple

The 181 occupies the market position for which splicers were originally developed – relatively fine yarns for industrial and conventional textile applications. The 182, with its wide range of formats and operating systems, is the ideal splicer for these lower counts.

Hand-held, fixed, or rail-mounted, the 182 can meet most factory needs, and if circumstances change, new 182 bodies to the required configuration can be printed quickly by Airbond. The splicer can be supplied with a blast timer, or with a flow control system which supplies low-pressure air to the blast chamber, while keeping full pressure for the cutters. The cutters are adjustable, to enhance performance.

The Model 182 sets a new standard as an effective and user-friendly tool for continuous-filament synthetics, particularly modern industrial fibres.

The range is simple, durable, and easy to maintain. The splicers can handle a wide range of yarn counts

Splice format	Ends opposed.
Industrial applications :	Composites processes such as filament winding, pultrusion, and most textile processes such as weaving, knitting, tufting and braiding.
Yarns:	Nylon, Polyester, Glass fibre, Aramid, Carbon, Synthetic C.F., Synthetic staple, Worsted spun and many more.
Yarn counts:	Up to 2000 tex.
Twist	Zero or low twist c.f. and staple.

# Getting started

## Model 182 – getting started

Please read this section before you start operating the splicer. The rest of the manual deals with maintenance, and with details of products; those sections will not be needed immediately.

Remove all packaging. For each splicer, you will have the appropriate splicing chamber – which will usually already be fitted.

Depending on what you have ordered, you may have some or all of the following:

- Additional splicing chamber(s)

- Optional hanger

- Optional hanging clip

- Optional flow control device

It may be useful to have a fixed place to store the splicer temporarily when the operator has finished, in which case you will have specified the “W” modification. This modification will change the splicer designation – the Model 182 H, for example, becomes the 182 HW. If it has been supplied, bolt the hanging clip to a convenient spot on a machine. The splicer can then be placed in the hanging clip when not in use. This reduces the likelihood of the splicer being dropped and damaged in service.

You may have chosen to have a flow control device fitted. In that case, you will have specified the “F” modification. This modification changes the splicer designation further – the Model 182 H, for example, becomes the 182 HF, and the Model 181 HW becomes the 182 HFW.

Connect the splicer to an air line.

Under normal circumstances, the line pressure should be around 6 bar. The line should preferably be fitted with a pressure regulator so that adjustment may be made to suit local needs.

Hold the splicer with the trigger button facing the body, and press the trigger with the thumb.

Look down into the splicer

Press trigger part-way down - see the pad move until it hits the chamber

Press trigger further - listen for the air blast

## Making a splice



Ends-opposed splices.

Suitable for higher-quality applications  
The Model 182 is designed to make splices of this form as standard

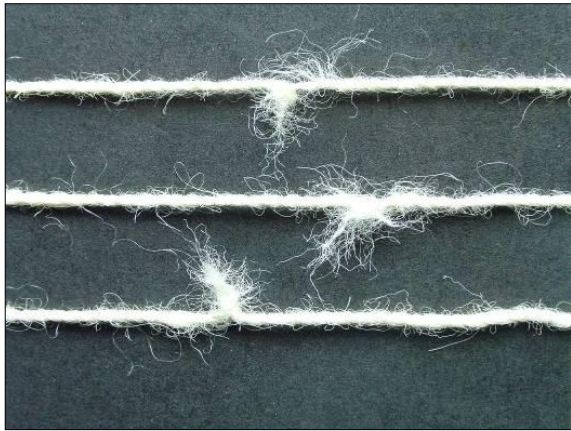

Ends-together splices.

Suitable for less critical applications  
The Model 182 is not designed from the outset to make splices of this form, but is able to do so if circumstances demand, and if appropriate splicing chambers are fitted.

## Splicer threading

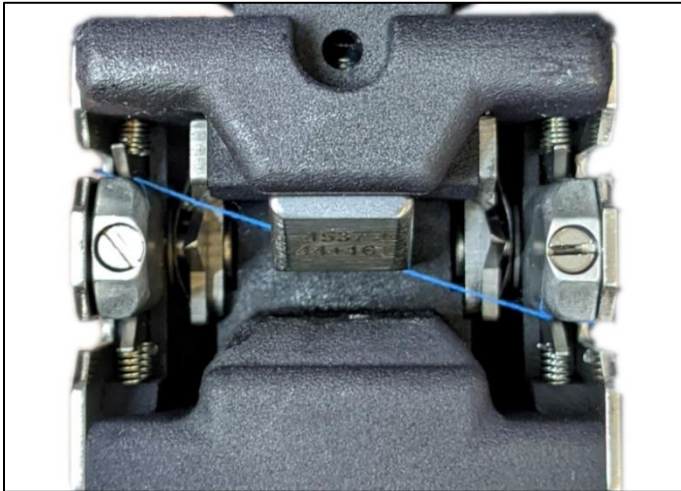

### Making an ends-opposed splice

#### First stage:

Present first yarn to splicer

The first yarn is placed in the splicer. The yarn enters from the left-hand side; it enters via the lower left clamp, and leaves via the upper right clamp.

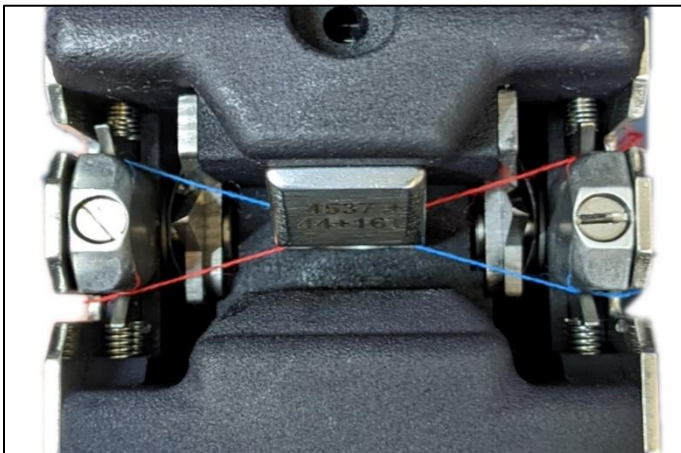

Second stage: present second yarn to the splicer. The second yarn is placed in the splicer. The yarn enters from the right-hand side; it enters via the lower right clamp, and leaves via the clamp at upper left.

Note the flat "X" form of the string-up



#### Third stage: make the splice

Press the trigger in one swift, single movement. If the splicer has no timer, press the trigger until the chosen blast period has elapsed. Then release it. If the splicer has a timer, keep pressing the trigger until the blast ceases automatically. Then release it.

#### Fourth stage: remove the splice

Once the splice is made, the completed joint is withdrawn and the waste ends discarded.



## Optimising splicing performance

The operator has a number of operating parameters which can be changed at will, so that the optimum performance may be achieved for a given situation. The following variations are possible:

- Change splicing chamber.
- Change air pressure.

The third parameter needs to be explained. All splicers of the 181 range are capable of dealing with a wide range of yarn counts. The splicer requires fewer chambers than most in order to cover its operating range. One reason for this flexibility is the technology of the splicing chamber; another reason relates to the special adjuster built into the trigger. The function of the adjuster radically affects the splicer performance..

The Model 182 separates the functions of cutting and blasting, two functions of a splicer which are usually closely linked. The splicer actually consists of two independent sub-systems within the same body.

- The right hand valve controls the movement of the chamber pad, and the entry of blast air into the splicing chamber. It does not actuate the knives.
- The second valve, the left hand one, controls nothing but the knives. The actuation of the knives is therefore completely independent of the pad/chamber operation.
- The knife control is effected by the rotation of the brass adjusting wheel.
- The adjustment of this feature has been made as simple as possible; the wheel is marked with numbers from 0 to 6 which may be “dialled up” according to the user's needs.

The operation of this cutting controls system is explained on the next page.

## Optimising splicing performance – other controls

### Blast timer models



This picture shows the Model 181 HT, Which can be supplied to special order.

It comprises two sections - the hand-held splicer and the timer box. In the illustration, both these elements can be seen clearly.

The blast time is easily adjusted with the dial on the timer box.

## Optimising splicing performance – other controls

### Flow models



See the flow adjustment screw on the back of the splicer – the white circle.

The flow adjuster is clamped in position by the black locking screw.

To adjust the flow control, release the locking screw and turn the flow controller. When the groove is in the vertical position as shown, there is maximum flow. When the groove is in a horizontal position, the flow is reduced to zero.

## Optimising splicing performance – yarn clamp pressure



All splicers of the 182 range are capable of dealing with a wide range of yarn counts. Yarn clamp pressure is a contributor to splicing efficiency.

The Model 182 has 4 yarn clamp pads. In this photograph, the splicer guide plate has been removed, so that the pair of clamp pads on the right-hand side can be seen. There is a similar pair on the left-hand side.



Here, one of the yarn clamp holders has been removed so that it can be seen clearly.

On delivery from Airbond, the clamps are set up as standard for mid-high count yarns.

The clamp pressure can easily be adjusted by rotating the yarn clamp adjusting screws.



In this photograph, one of the adjusting screws is being turned by a hex key.

Rotating clockwise increases the clamp pressure - needed for higher count yarns to keep the yarn under control during the splicing process.

Do not rotate the screw all the way in, as the yarn clamp will become damaged and unusable.

Rotating anti-clockwise decreases the clamp strength. This is needed for the fine yarns, which require little pressure to keep them under control.

Reduction of clamp pressure is important for fine, weak yarns; too high a pressure will damage filaments – and possibly break the entire yarn – during string-up.

Too low a clamp pressure, on the other hand, can lead to a different problem: clamp pressure is too low, the yarn will get drawn into the splicing chamber during the splicing process, giving a splice with a poor appearance.

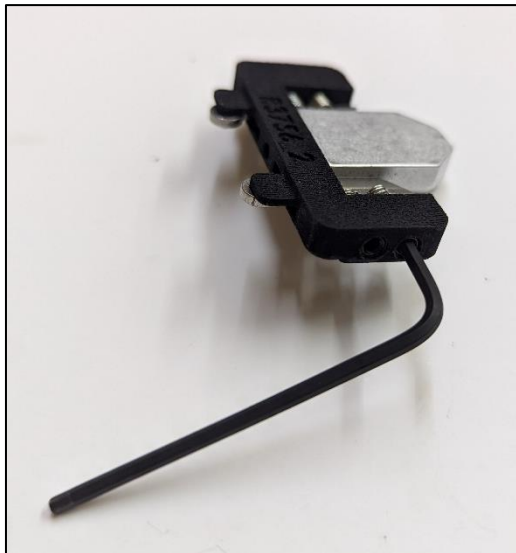

## Important service information

Apart from accidental damage, and the occasional replacement of cutters, the Model 182 requires very little attention. However, one aspect of maintenance should NEVER be neglected. The upper bore, in which the chamber pad moves, needs regular lubrication. The frequency of lubrication depends upon the nature of the factory environment and the workload on the splicer.

As a general rule, the cap and pad assembly should be removed and greased with Molykote 111 (available from the company) at least once per month. The service interval should be reduced if the splicer experiences very heavy work loads.

# Model 182 – General product information

## Introduction

The 111 Series of splicers has been an important product in the Airbond range for many years. It was the outcome of a programme to apply new design principles to ends-opposed splicers. Improved splicing chambers were developed, and a new, adjustable cutting system was fitted. The result was a new ends-opposed splicer which was vastly more flexible than its predecessors.

The 111 Series was designed to be as uncomplicated as possible, with a simple, durable body structure. For simplicity of manufacture and maintenance, the 111 Series was developed, using modular principles of design. All of the Model 111 splicers had a common base unit. Parts were added to the base unit, to make up the complete splicer assembly as needed. The splicer was therefore is available in many different forms, to suit different customer needs.

- All 111 Series splicers had a simple straight-line string-up.
- All had an unusually simple construction.
- Simple construction leads to simple maintenance; the splicer in its basic form could be completely dismantled and re-assembled in about twenty minutes.
- The splicer had a very strong construction; it resisted damage in service very well.
- The splicers contained new and patented technology, and need a smaller range of splicing chambers than splicers of earlier generations.

In its quest for continuing improvement, Airbond has adopted 3d printing manufacturing technology, and this has enabled us to transform the splicer. No longer do we need the modular construction (which was not quite as flexible as customers required.) Instead, printing enables Airbond to make a multiplicity of designs – almost “designing to order” to meet customer needs.

So, from this latest phase of development has emerged the 182 Series of splicers. The 181 Series splicers are the successors to the Model 111s; similar in appearance, but radically different in detail. Stronger than the 111s, but not much more than half the weight, the 181 Series will be much more comfortable for operators over a busy shift.

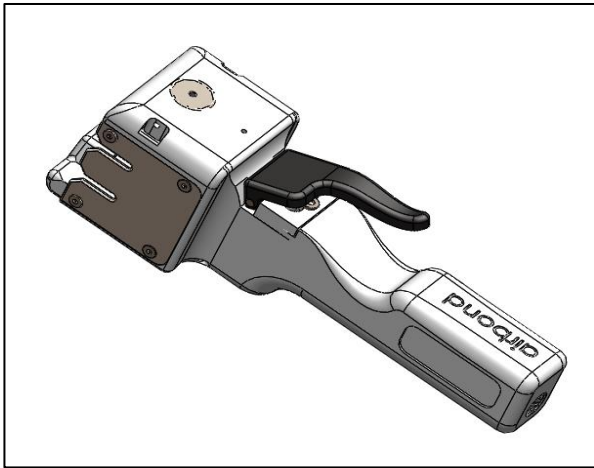

These two photographs show that, while the 182 Series splicers are replacements for the Model 111,- they are similar in overall appearance - they are very different in their construction.

Most notably, the 182 is made in one piece – handle and splicer body are printed all-in-one, whereas the 111s body and handle are separate items – connected by 100 mm through-bolts.

The 182 is lighter, and because most of the weight saving is in the splicer body, it is better-balanced and easier to handle,.



The 111 Series splicers make a joint of the “ends-opposed” form. This type of splice generally has excellent appearance, whether used on “well-behaved” yarns such as multi-filament nylon, or on more difficult yarns such as those made from staple blends.

This illustration shows a splice on wool worsted.





## General description

Being printed from tough PA12 polymer, the new Model 182 Splicer is capable of standing up to heavy-handed use, but is still much lighter than its predecessor, the 1-11.

The Model 182 Splicer has a number of components mounted on a body in which airways conduct the compressed air for the splicing action.

Trigger - pressing the trigger initiates the splicing operation.

Valve - operation of the trigger moves the valve allowing compressed air to pass into the body head for splicing.

Pad - in the initial operation, compressed air closes the pad onto the splicing chamber prior to the splicing operation.

Splicing chamber - having a profiled recess on the front face which, with the closed pad, forms a chamber in which the splice is made. Air enters into the chamber to form the splice.

Guide plates - the plates provide a means of guiding the yarn across the splicing chamber; movable knives exit side enables the yarn to be severed during splicing.

Automatic cutting – there are 2 sets of knives on either side of the chamber to cut away the waste ends.

The Model 182 is simple and easy to maintain. Moreover, its construction is such that it is extremely rugged, and requires very little attention in service. The splicer has revolutionary and patented splicing chamber technology, which enables the splicer to make joints in a wide range of yarns without any change - in general, there is no need to change chambers when changing yarns to a certain degree.

# 181 Model range

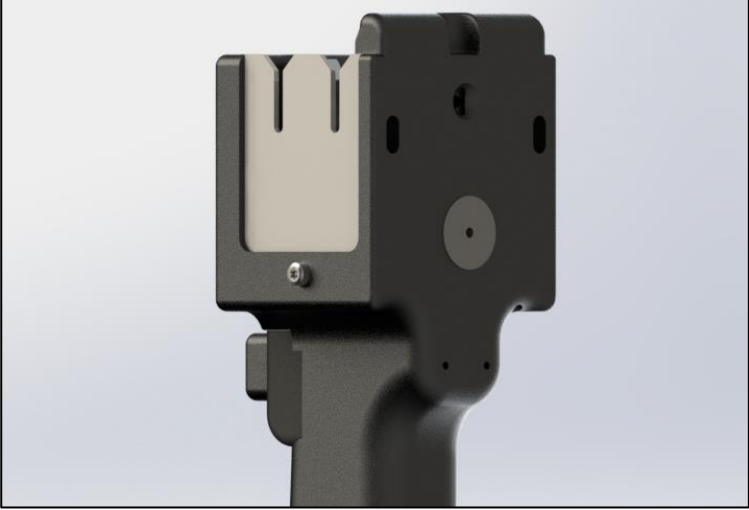

The body of the Model 182 H.

The entire structure is printed as one component.

This shows the Model 181 H body – the simplest of the range, with provision for neither a hanging assembly nor a flow control system.



The body of the Model 182 HW.

The entire structure, including the hanging wedge, is printed as one component.

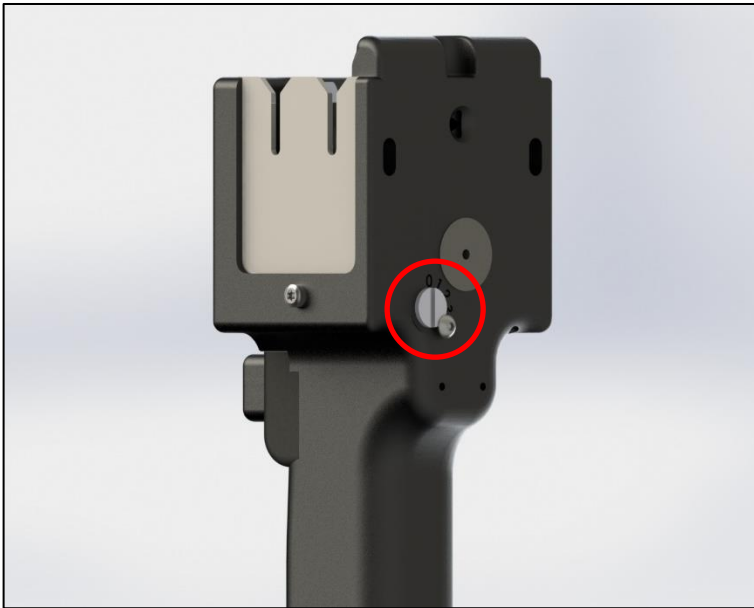

The body of the Model 182 HF.

The entire structure is printed as one component.

This shows the Model 182 HF body. It has no hanging wedge, but – just above the of of the handle section – is a small hole. This is the location of the flow control system.

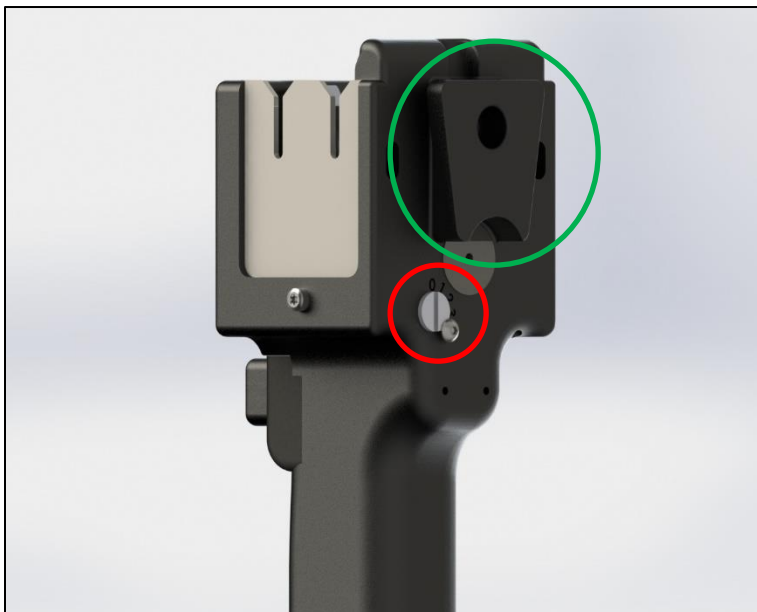

The body of the Model 182 HFW

As with the rest of the 182 range, the entire structure is printed as one component.

This shows the body of the Model 182 HFW - the splicer with most built-in features..

Clearly visible are the hanging wedge and the port for the flow control system

## 182 Model range

The list below is indicative, not exhaustive. Customers may specify combinations of features according to need.

Examples:

- 182 H 182 splicer with a 100 mm handle and no accessories
- 182 HW 182 splicer with a 100 mm handle and hanging kit
- 182 HF 182 splicer with 100 mm handle and flow control
- 182 HFW 182 splicer with a 100 mm handle and hanging kit and flow control
- 182 HM 182 splicer with 100 mm handle and magnet
- 182 HT 182 splicer with 100 mm handle and timer box
- 182 HTM 182 splicer with 100 mm handle with magnet and timer box
- 182 HTW 182 splicer with 100 mm handle, hanging kit and timer box

Example:

Splicer Model 182 H

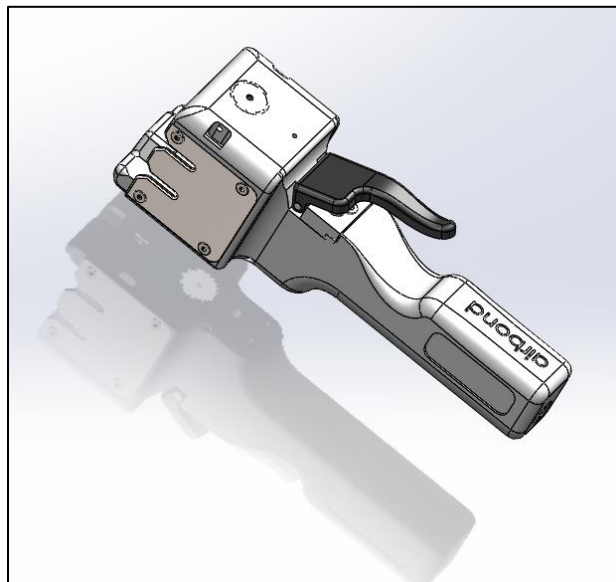

# Model 182 – Maintenance

## Changing splicing chambers

The Model 182 can splice a wide range of textile yarns on a single splicing chamber, so it is rarely necessary to change chambers. Nevertheless, you will sometimes need to remove the splicing chamber - during routine maintenance, or because the splicer has become fouled with fibres,



To release the splicing chamber, remove the single fixing screw Item 705 from the rear of the splicer body, when the splicing chamber can be lifted clear of the splicer.

Usually, it is not necessary to remove the yarn guide side plates, but if the interior of the splicer is particularly filthy, removal of the plates will help cleaning.

This photograph shows a Model 182 HWF; the hanging wedge of the Model 182 can be seen, printed as part of the body, rather than a separate item as on the old Model 111.

**WARNING:** If the splicing chamber is removed while the splicer is connected to the air supply **DO NOT** press the trigger; the pad will be blown out of the main chamber. There will almost certainly be damage to the extension spring.

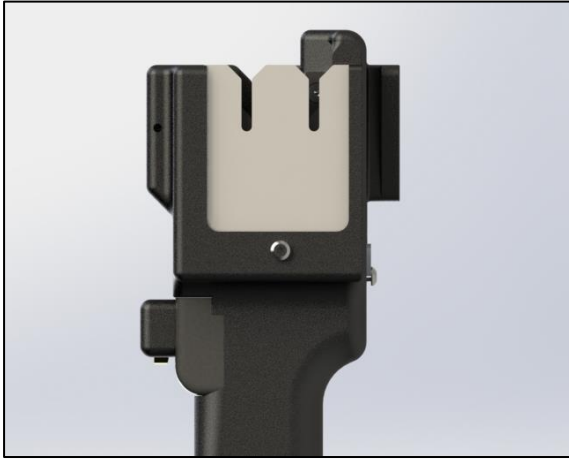

Removal of yarn guide plate left side.

The guide plate is attached to the body by a single M3 self tapping screw, Item **XXXX**.

Remove it, and the guide plate can be lifted off.

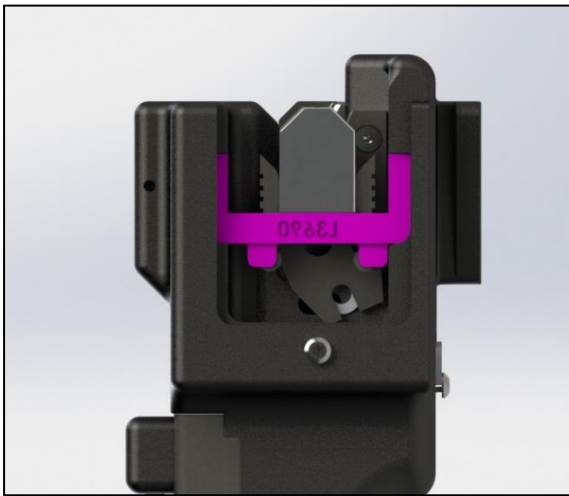

Removal of yarn clamp assembly.

Once the guide plate has been removed the yarn clamp assembly is revealed..

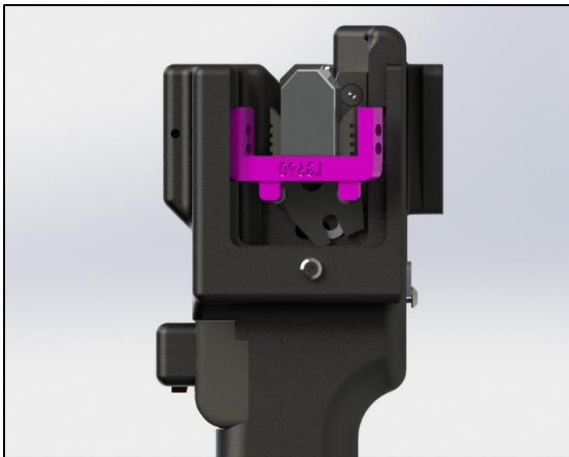

Removal of yarn clamp assembly.

The clamp should be removed by pulling out the back side first. Accumulated dirt may make it difficult to remove; in that case it can be levered out by careful use of a small tool such as a screwdriver.

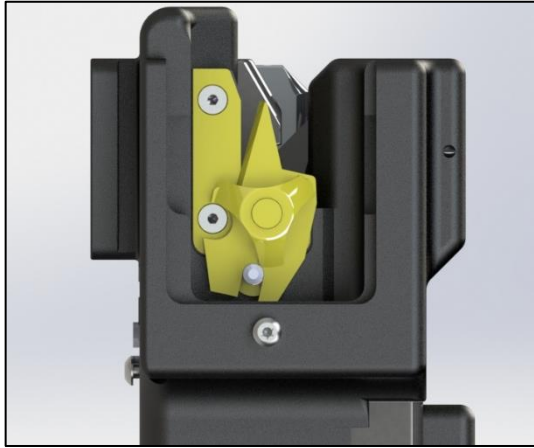

Repeat the operation on the other side.

This will leave the cutter assemblies visible and accessible.

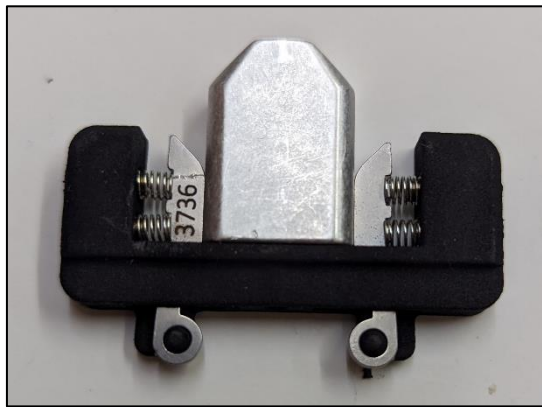

Dismantling of yarn clamp assembly.

Here is the one of the yarn clamp assemblies, after removal from the splicer body.

Each assembly is a pair of silver metal clamps, which are spring-loaded and adjustable for compression.

The clamps float free on small coil springs. Clamp pressure is adjusted by turning small grub screws.

The movement of the yarn clamps is moderated by the metal pillar in the centre of the clamp. This can be removed by using a flathead screwdriver.







Dismantling of yarn clamp assembly.

The yarn clamp pillar is able to be removed once the flathead screw is removed.

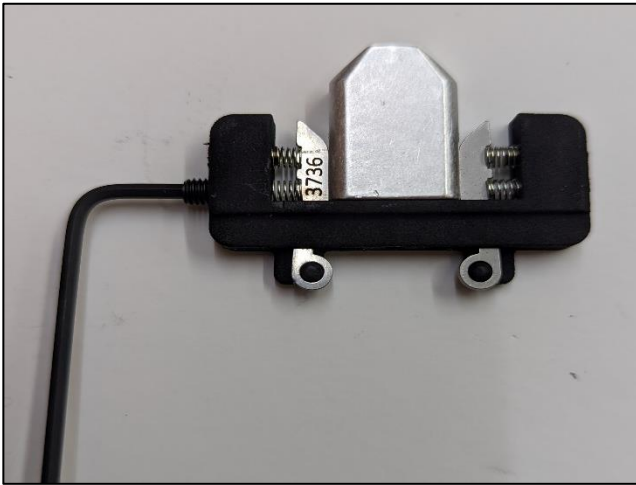

Dismantling of yarn clamp assembly.

Release the yarn clamp adjuster screw  
The clamp pressure adjusting screws fit in small threaded holes; they are removed using a suitable hex key.

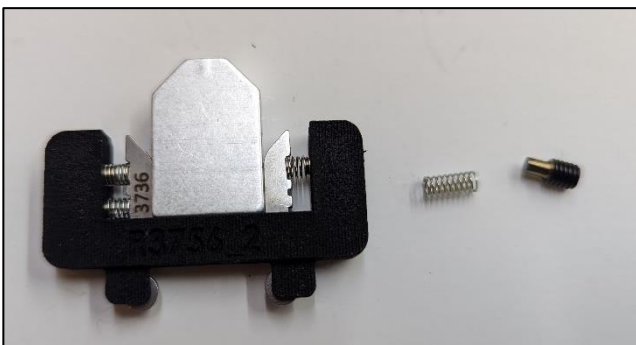

Yarn clamp assembly dismantled

This illustration shows the yarn clamp assembly showing the spring and grub screw order.

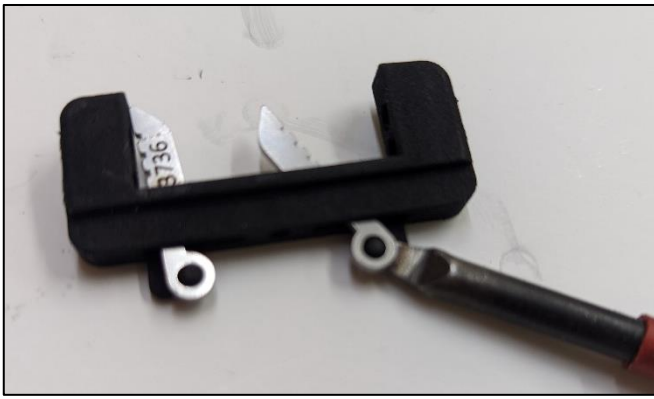

Dismantling of yarn clamp assembly.

The yarn clamp pillars are able to be removed by using a flathead and levering up the bottom, pushing up and sliding them out.

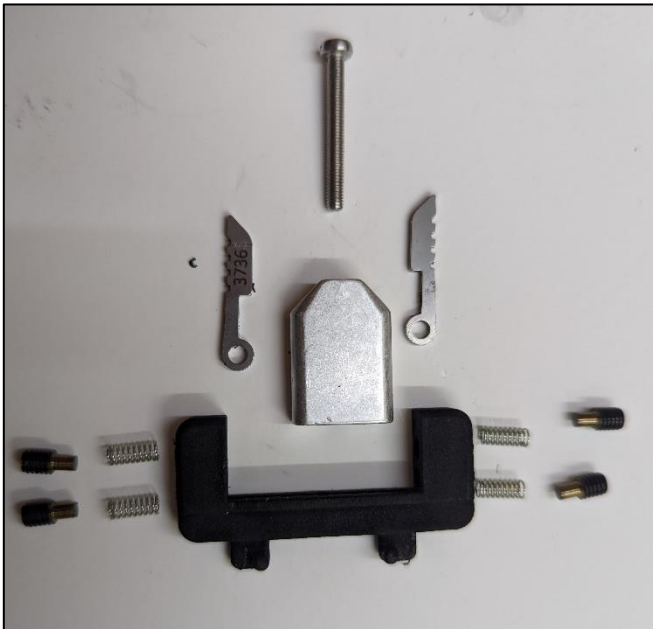

Yarn clamp assembly dismantled

This illustration shows the yarn clamp assembly, dismantled. From the top:

- M4 flat heads screw
- Yarn clamp levers
- Yarn clamp Pillar
- Yarn clamp pressure springs
- Grub screws
- Yarn clamp holder



Removal of knife assembly.

The knife assembly consists of two cutters, a pivot pin, a three-legged compression spring, and a circlip. Dismantling starts with the removal of the circlip, which can be levered off with a suitable small tool.



Removal of knife assembly

The assembly after removal of the circlip.

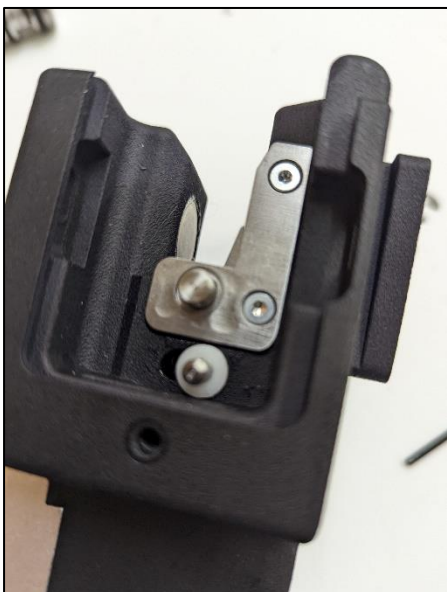

Removal of knife assembly

Lift off the three-legged spring

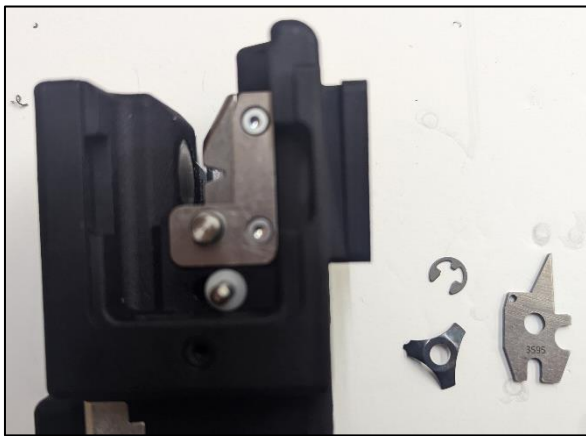

#### Removal of knife assembly

Lift off the moving knife.  
Once the moving knife has been removed, the securing screws for the fixed knife are exposed.



#### Removal of knife assembly

Undo the fixed-knife securing screws.



#### Removal of knife assembly

Once the securing screws have been removed, the fixed knife can be lifted out of the splicer body. **DO NOT** lose the small white washer at the left side of this photo. The washer is essential for maintaining the correct scissor-angle on the knives.

#### Removal of knife assembly

Repeat the operation on the other side of the splicer body.

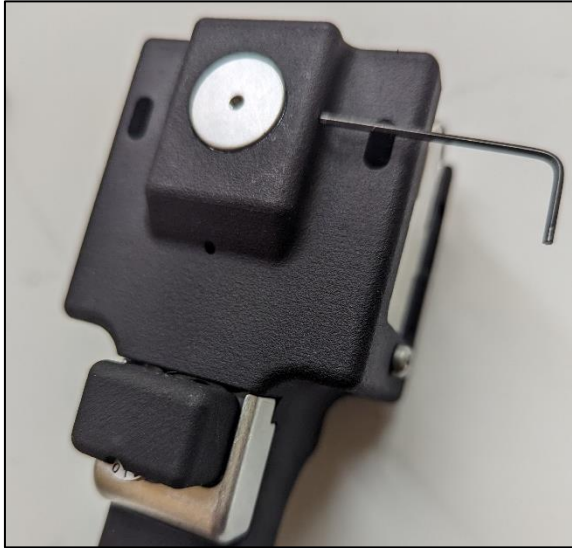

Removal of upper sealing plug and pad assembly.

The upper sealing plug is retained in the splicer body by two M3 x 10 socket head set screws, Item 1128. Undo the set screws using a hexagon wrench.



Removal of upper sealing plug and pad assembly.

Once the set screws have been removed, the upper sealing plug / pad assembly can be withdrawn as a single unit.

The assembly can be released, either by the use of a threaded rod, screwed into the sealing plug, or by applying gentle pressure to the surface of the closure pad with a suitable tool.



Removal of upper sealing plug and pad assembly.

The upper sealing plug / closure pad assembly, withdrawn from the splicer body.



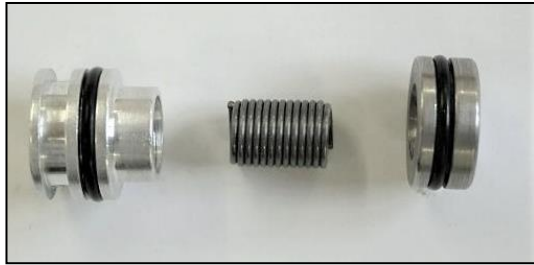

The pad is tethered to the upper sealing plug by an extension spring. The extension spring is screwed into the sealing plug, and the pad screwed to the spring. When the splicer has been dismantled, we recommend that the spring always be replaced.

Unscrew the pad from the spring, and the spring from the sealing plug. Discard the spring. Thoroughly clean and de-grease the screw threads in the sealing plug and pad.

We recommend that a special flat-tipped M10 tap be used to clean out the threads in plug and pad.



Before reassembly, ensure that the sealing plug, spring, and pad will fit together correctly. We recommend that the components first be 'dry assembled'.

Screw the spring into the sealing plug until four or five coils of the spring remain exposed. Screw the pad onto the spring for a few turns.

Check that the pad is approximately parallel to the sealing plug and that a gap of 1.5 to 2.0 millimetres between sealing plug and pad can be achieved. If the components are markedly out of parallel, discard the spring.

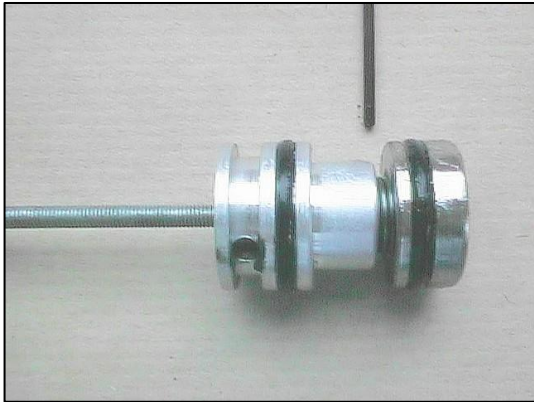
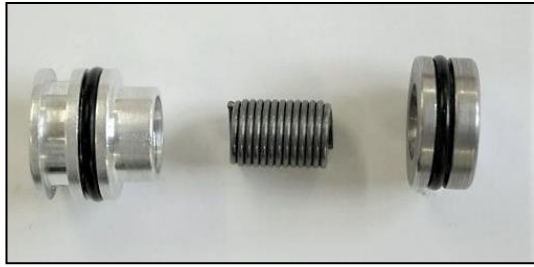

If the 'dry assembly' is satisfactory, dismantle and repeat the operation using adhesive. Apply a drop of Loctite Structural Adhesive 326 to the coils at one end of the spring, and screw the spring into the sealing plug until four or five coils of the spring remain exposed.

Apply more adhesive to the exposed coils of the spring and screw the pad onto the spring, ensuring that the gap between sealing plug and pad is roughly parallel and is between 1.5 and 2.0 mm. Allow the adhesive to cure for about 30 minutes.

Before replacing the assembly, lightly smear the 'O' ring in the pad with Molykote grease. Apply a small amount of grease to the surface of the main bore.



### Removing trigger and surround

The trigger, Item 1508, is retained by a single socket head screw, Item 501, whose tip fits into the body. Locking a trigger pin 182, item 1521, in place.

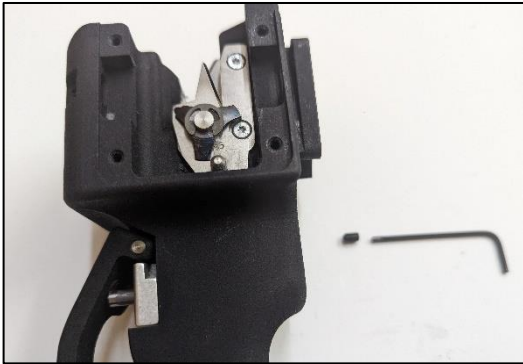

### Removing trigger button and surround

This photo shows the grub screw that has been removed from the rear of the splicer body. Once this screw is removed it will then be possible to push the trigger pin out and remove the trigger completely.

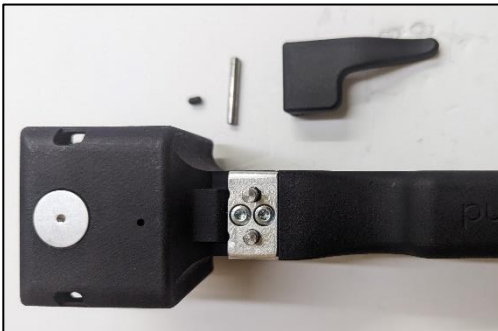

### Removing trigger button and surround

Now that the trigger is removed it will now be possible to remove the trigger housing, item 1840. Two screws, item 1127, hold the housing and once removed you will be able to access the valves.



### Removing trigger button and surround

The trigger housing removed from the splicer body. The air valve, item 1104, and knife valve, item 1105, stems are now fully accessible.



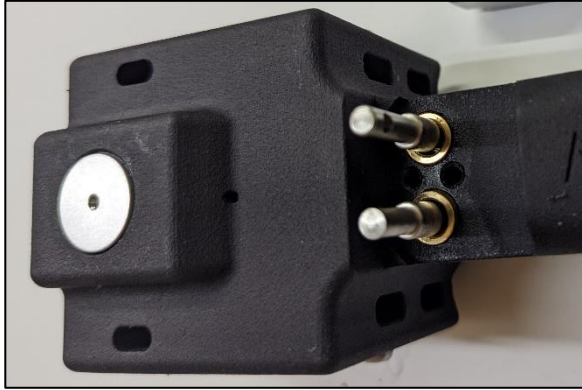

### Removing trigger button and surround

Withdraw the two air valves, Item 1522 and 1523. Check that the valve stems are coated with Molykote grease; if not, then be sure to re-grease the valve during reassembly.



### Removing valves, spacers, and O-rings

Using an appropriate tool, withdraw the O-rings, shells, and compression spacer from the valve bore in the splicer body.

The upper photo shows the valve, Item 1104, which controls the actuation the air blast. Note the small hole near the end of the valve stem. This is the hole which locates the socket set screw restraining the trigger button.



The lower photo shows the valve, Item 1105, which controls the cutters. Note that it is shorter than the air blast valve, and has no hole for a set screw.

Each valve has a small spring, Item 787, housed in a recess at the end of the valve. These springs return the valves, and the trigger button, to their rest positions after the splicing action is complete. The return springs fall out quite easily; they can be kept in position by applying Molykote grease to the recess in the end of the valve.

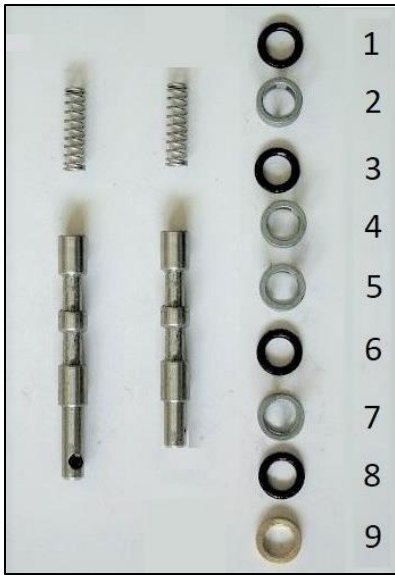

### Removing valves, spacers, and O-rings

Valves and accessories separated. The small components, and their assembly sequence, are the same for both valves.

Note the brass spacer, numbered 9, Item 902, at bottom. This spacer is important; it compresses the O-rings, so that the assembly seals properly.

Sequence for reassembly; 1 – 9. First item placed in the bore is the O-ring (1), Item 264, followed by the Shell (2), Item 276, and so on to the Spacer (9).

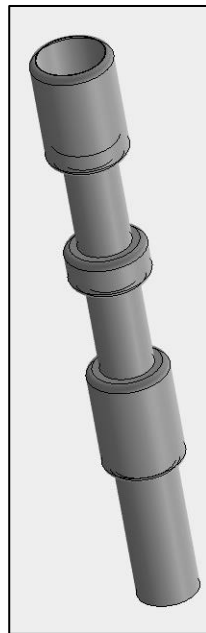
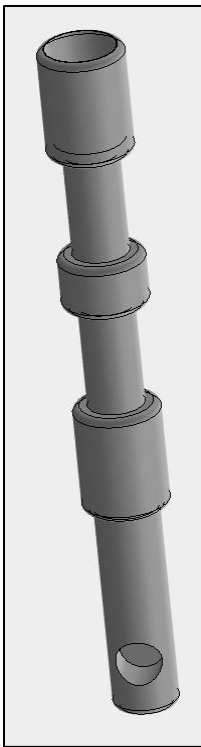

### Removing valves, spacers, and O-rings

The valves in more detail.

The drawings show clearly the recesses in each valve for accommodating the return springs, and the hole in the stem of the air blast valve.

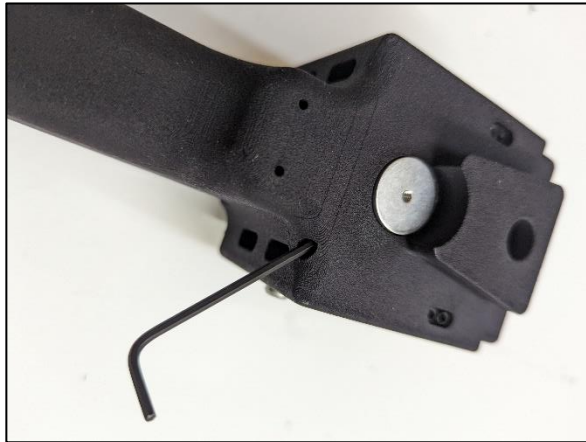

#### Removal of lower sealing plug and knife drive

Here is the splicer body, with the upper sealing plug and pad removed. The lower sealing plug is secured to the body with two socket head set screws, Item 502. One is angled as seen in the picture and the other is from above in the picture shown below



#### Removal of lower sealing plug and knife drive.

Release the set screws using a hexagon key.



#### Removal of lower sealing plug and knife drive.

Once the screws have been withdrawn, the lower sealing plug, Item 1098, can be removed from the body. This is most easily done by inserting a length of threaded rod into the tapped hole in the plug – which then can be extracted without difficulty.

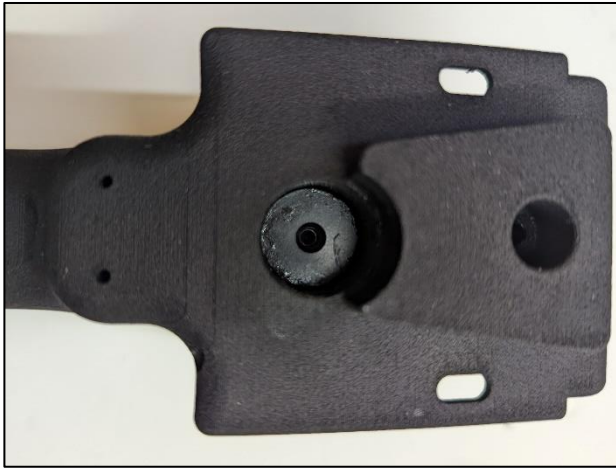

Removal of lower sealing plug and knife drive

With the lower sealing plug removed, the knife drive piston, Item 1097, is accessible. It is the white component, here visible in the lower large bore.

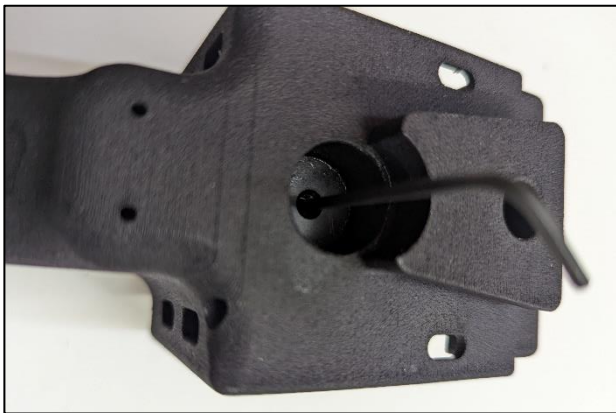

Removal of lower sealing plug and knife drive.

Before the piston can be removed, it will be necessary to remove the knife drive shaft, Item 1131. This shaft is secured with a socket set screw, Item 869. Release the knife drive shaft by unscrewing the socket set screw.



Removal of lower sealing plug and knife drive.

With the securing screw loosened, the knife drive shaft can be pushed out of the splicer from either side.

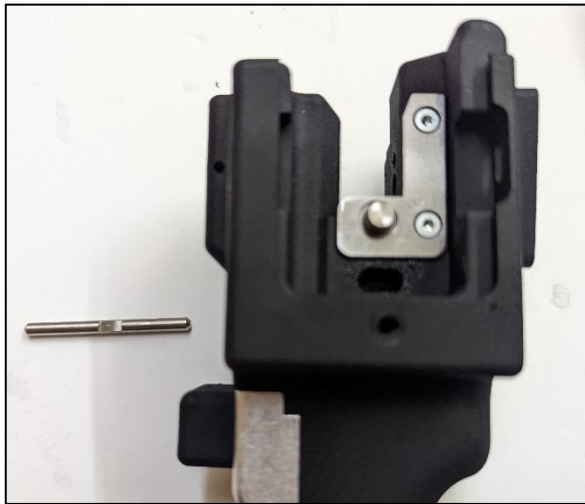

Removal of lower sealing plug and knife drive.

This photo shows the knife drive shaft, removed from the splicer body.

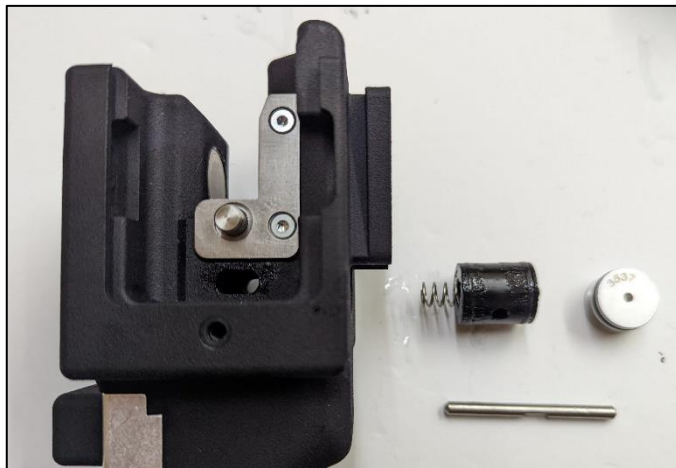

Removal of lower sealing plug and knife drive.

Using the same threaded rod as that used for the lower sealing plug, the knife drive piston and its associated return spring, Item 530, can be removed from the splicer body.

Removal of lower sealing plug and knife drive.

The splicer showing the knife drive shaft, the knife drive piston, and the return spring, after removal.





### Removing flow control assembly

The flow control screw is the white component, Item 1162, shown here. It is secured in position by the black locking screw, Item 1193, and the locking washer, Item 556.



### Removing flow control assembly

Unscrew and remove the black retaining Screw.

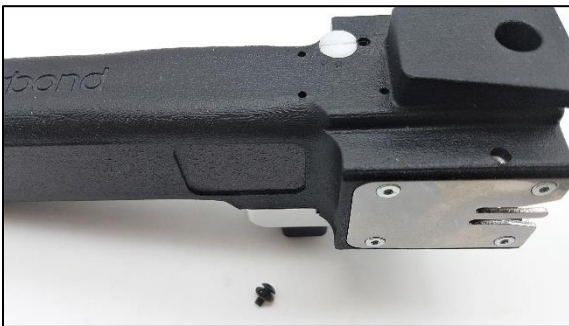

### Removing flow control assembly

The black retaining screw is removed.

The flow controller can now be lifted out of the splicer body. A small amount of (careful) levering may be required, as there is certain to be some frictional resistance – the flow-control O-ring, Item 788, is a close fit in the body.

## Compressed air

Pneumatic splicers are operated by compressed air. Therefore the air supply must be appropriate.

The following points are important:

Splicers generally operate at a pressure between 3 and 8 bar.

Pressure may vary according to application, but it must be as uniform as possible.

The air supply should be reasonably dry and clean, with the lowest possible flow resistance.

Because the time taken to make a splice is short, transient pressure drops associated with other demands in the mill may become important,

When the splicer is operated, line pressure at the splicer head normally drops by about 1 bar. If there are restrictions in the line, air will not be replenished, so that the pressure drop will be greater; weak splices may result.

Compressed air installations should therefore be designed to minimise pressure drop.

Never use narrow-bore supply tube; this introduces resistance.

When there is doubt about the quality of the air supply system, a pressure gauge should be fitted - temporarily - as near as possible to the splicer, so that static pressure and pressure drop can be monitored. This is particularly desirable in an installation which uses long lengths of coiled hose; losses in such hoses tend to be significant.

Sometimes, static line pressure is known to be adequate, but there sometimes serious problems with transients. Then it may be useful to fit a few metres of wide-bore pipe or other form of plenum, close to the splicer. This will act as a reservoir, to minimise pressure drops while the splicer is in use.

Do not fit lubricators in the line very near to the splicer; an excess of oil on the yarn may weaken the splice.

## Compressed air and safety

All our splicers have been designed with safety in mind. The few moving parts have been enclosed or shielded to reduce the possibility of injury to the operator. In normal use, the only component which is in any way a source of hazard is the knife assembly. By design, however, the blades are difficult to reach, and are not dangerous in any normal circumstances. Knives represent a hazard only during removal and disposal. So, in normal use, the splicers present no risk.

However, the splicers do use compressed air, and that has the potential to cause injury. Compressed air is dangerous: avoid any bodily contact with it.

Always follow the safety precautions recommended by the compressor manufacturer. Always ensure that unions and connectors are fully tightened and sealed, and that there are no leaks.

Check the conditions of air supply lines on a regular basis. Always ensure that any flexible hoses are unblemished; if there are any cuts or abrasions to the outer surface of the hose, stop using the splicer and have the hose replaced by qualified personnel.

Do not look into the working parts of the splicer when it is being operated.

If a splicer malfunctions, do not use it until it has been repaired by qualified personnel.

For maintenance staff, additional advice is necessary. When cleaning or servicing is being carried out, access to the internal mechanism of the splicer is essential. Under these circumstances, maintenance engineers will be at greater risk than ordinary users. The engineer should adhere strictly to the following guidelines:

- Before undertaking any service work, disconnect the splicer from the air supply.

- Under normal circumstances, always refit safety covers before reconnecting the splicer to the air supply.

- Under exceptional circumstances, it may be necessary - for test purposes - to reconnect the splicer to the air supply without its safety covers.

- While the splicer is being tested, wear protective gear and exercise due caution.



## Compressed air and noise

A splicer uses compressed air, which for a brief period - about 1 to 2 seconds – is vented to atmosphere while the splice is being made. Air at perhaps 7 bar pressure escapes through a small blast hole, creating intense turbulence in a small volume.

Noise is inevitable.

Typical maximum noise levels vary from 80 db to 98 db, depending on the splicing chamber. Some chambers are quieter than others, simply because they have a smaller blast-hole, and allow less air to emerge.

Our noisiest splicer, with the biggest blast hole in our range, generates a noise spectrum as shown in the table below:

Hz	63	125	250	500	1000	2000	4000	8000	16000
dB	47	52	57	63	74	89	92	93	95

In practice, splicers are barely noticeable in a textile mill. This is because the other mill machinery tends to be very noisy, and the sound of the splicer is lost in the general noise. Also, the blast only lasts for about one second.

Nevertheless, in compliance with UK health and safety regulations, we recommend that ear defenders (to local standards equivalent to British Standard 6344 Part 1) be worn.

# Troubleshooting

Trouble with splicers generally takes one of two forms: poor splicing or component malfunctioning.

## 1) Splicing performance.

If there is no apparent damage to the splicer, there may still be something subtle, which cannot easily be seen. It will be best, however, to look at the possible causes which are easy to spot.

These include:

Simple checks:

- Has yarn specification changed markedly? The splicer is very flexible, but it can't do ALL yarns on one configuration. If the yarn has changed, take another look at your operating procedures and – possibly – the splicing chamber specification. If, for instance with glass, the yarn count has remained constant, but the level of sizing has increased, it may be necessary to increase air pressure and/or increase the duration of the blast.
- Is the air pressure as it should be? The line pressure may have changed – upward or downward. Excessive air pressure will cause bad filamentation, and low air pressure will result in weak splices. Consideration should be given to using flow-control versions of the splicer.
- If you have a splicer with flow control – has the position of the flow controller shifted? This can happen if the clamping screw has come slightly loose.
- Are there any obstructions in the main air line or in the splicer itself? It has been known for foreign matter to get into the air-line, and to obstruct the chamber blast hole; this is usually accompanied by a reduction in the noise level of the blast.
- Have operating procedures changed? If the procedure changes, performance will change.
- Are the splice ends being trimmed properly? For perfect performance, all splicers rely on the waste ends of yarn being cleanly trimmed. Good cutting performance must be maintained at all times. (See more details on next page for information on cutting issues and how to resolve)
- If fitted, has the timer calibration changed?
- Are the yarns slipping in the clamps? Sometimes the yarns will slip, and "balloon" in the region between clamp and chamber, giving a bad splice.

## More detail

### Cutting problems:

- The cutters may have become blunt. The cutters are manufactured to a high standard (sometimes tipped with tungsten carbide) but it is inevitable that, after some service, the edges will become dull. Poor cutting – and splicing – performance is then inevitable.
- It is impossible to give exact guidance on cutter life, because materials vary so much; a soft wool may not trouble the cutters for a year, while an aramid will always pose problems. Remember that the cutters are designed to be re-sharpened at the customer's premises; the straight edges are quite easy to re-grind – and perhaps 5 or 6 re-sharpening cycles will be possible before the knives have to be replaced.
- Finally, the washer, Item 1110, which is used to set the scissor angle, may have been lost during maintenance; that omission will guarantee poor cutting. The presence of the washer can be verified by removing the yarn guide plate and the clamp assembly on each side; the white circle can be seen in this photo at the base of the moving knife, below the number "2"



### Knife travel:

- When the splicer is operated, and the knives move, there should be reasonable overlap of the edges in the cutting zone. If there is no overlap, there are a number of possibilities:
  - The knives may have been re-sharpened too many times. Remove the knives and replace with new.
  - The shaft may be a sloppy fit in the pocket at the base of the moving knife - this can happen if either the knife slot or the peg is worn. Replace knife or peg as appropriate.
  - The knife piston may be sticking. Remove piston, as in the main text. Service or replace.

### Knife and accessory wear/damage:

- The knives may appear to be satisfactory, but there may be damage to the cutting edge at its lowest point. This is rare, but may happen if something has happened to force the knives over into an excessive scissor angle. Such misalignment causes chipping of the cutting edge where contact is first made. Replace the knife, as in the main text.
- Check for correct seating of the compression spring. If it is not seated correctly, remove and re-seat, as in the main text. Check to see whether the arched compression spring has become flatter than normal. If it has, remove the compression spring, and replace with new.

## 2) Sticking closure pad

Occasionally, the main valve in the splicing unit may stick. This could be the result of some form of damage to the internal components, but the explanation is normally much simpler; a lack of lubrication around the O-rings which seal the pad assembly, or an extension spring which has come adrift.

Remove the entire valve / O-ring assembly from the splicer unit, as shown in the main text. Clean the components and the surface of the large bore with a small quantity of light solvent

Examine the components for signs of damage - particularly a damaged or displaced O-ring, or extension spring. If there is damage to any of the components, proceed as in the maintenance section of the main text, replacing components as appropriate.

Examine the surface of the large bore. Minor scuffing - the stuff of normal wear and tear in service - should be of no consequence. Look closely, to determine whether the bore surface is scratched. This is a very rare occurrence, usually associated with an earlier rebuild having gone wrong. Minor scratching can generally be rectified with careful use of a reamer.

When any faults have been eliminated, reassemble as in the main text.

## 3) Poor cutting

Good performance from the cutting knives is essential for satisfactory splicing efficiency.

Most important; is the yarn simply too big or too tough for the splicer? First, there is a simple physical limit to the size of what can fit into the knives. Second, certain materials pose big problems, because of their physical properties. Kevlar, for instance, will blunt standard steel knives very quickly.

Obviously, all knives will eventually become blunt, even in perfectly normal service. If the poor cutting performance is simply a matter of long service, new cutters can be purchased from Airbond. Alternatively, provided that the knives have not worn too far, we can offer a sharpening service.

## Model 182 Splicer - Parts list

Description	Item No.	Part No.	Quantity
Knife spring	241	201-1088	2
'O' Ring - BS010	264	01-10-10	8
Shell for air valve-43004-A3	276	2200-43-04	8
Yarn clamp spring	307	301-1007	8
M3 x 6 socket set screw	502	18-13-06	1
Knife piston return spring	530	10-136-013	1
Air valve return spring	787	10-136-018	2
M4 x 6 socket set screw	869	17-14-06	1
Spacing bush	902	10-133-114	2
Extension spring	904	10-136-113	1
'O' Ring RM0140 – 20	905	02-14-20	5
Molykote 111 100g tube	919	201-9993	SPECIFY
Blast valve & yarn clamp adjusting screw	1017	10-138-118	9
Locking pad	1039	10-111-114	1
M4 x 4 socket set screw	1040	10-138-114	1
Knife piston	1097	10-113-119	1
Lower sealing plug	1098	10-135-128	1
Upper sealing plug	1102	10-135-126	1
Knife pivot	1106	10-137-149	2
Spacer-moving knife	1110	10-133-118	2

Trigger button	1111	10-114-102	1
R.H. moving knife	1022	10-106-129-1	1
R.H. fixed knife	1023	10-106-130-1	1
L.H. moving knife	1024	10-106-129-2	1
L.H. fixed knife	1025	10-106-130-2	1
Splicing chamber		To be specified by customer	1
Circlip	1124	65-15-21	2
M6 x 4 socket set screw	1126	17-16-04	1
M3 x 10 socket set screw	1128	17-13-10	3
Knife shaft 1-11	1131	10-137-150	1
M3 x 8 torx cap head self tapping screw	1190	19-43-08	2
M4 x 8 torx cap head self tapping screw	1194	19-44-08	2
M4 x 12 socket cap head screw	1237	11-14-12	2
Pad 114	1405	10-113-111	1
Trigger 182	1508	10-133-169	1
Yarn clamp LH 181	1509	10-133-170	1
Yarn clamp RH 181	1510	10-133-171	1
Side plate 181	1513	10-105-156	2
Yarn clamp pillar 181	1514	10-105-157	2
Yarn clamp lever 181	1515	10-105-158	4
M3 x 25 cheese head slotted screw	1520	14-43-25	2
Trigger Pin 182	1521	10-182-30	1
Air valve-blast 182	1522	10-182-121	1
Air valve-knife 182	1523	10-182-122	1
M4 x 22 countersunk socket head screw	1632	12-44-22	1
Trigger housing 182	1840	10-121-111	1
Splicer body – 182H	1516	10-133-174	1
Splicer body – 182HFW	1526	10-133-180	1
Splicer body – 182HF	1527	10-133-181	1

Description	Item No.	Part No.	Quantity
<b>Hanging Assembly parts</b>			
Splicer holding clip	170	201-1199	SPECIFY
Splicer body - 182HW	1517	10-133-175	1
<b>Flow Control parts</b>			
M3 Washer	556	91-22-03	1
O-ring BS006	788	01-10-06	2
Flow restrictor valve	1162	10-113-114	1
Flow Restrictor Valve Assembly	1163	10-113-114A	1
Splicer body - 181HF	1177	10-133-124	1
M3 x 6 torx cap head self tapping screw	1193	19-44-06	1
<b>Timer Control parts</b>			
Timer box assembly	1168	10-119-110	1
Splicer body - 182HT	1518	10-133-176	1
Splicer body -182HTW	1519	10-133-177	1

# Model 182 Assembly

